

GRAPPA

MÜLLER. MADE IN GERMANY.

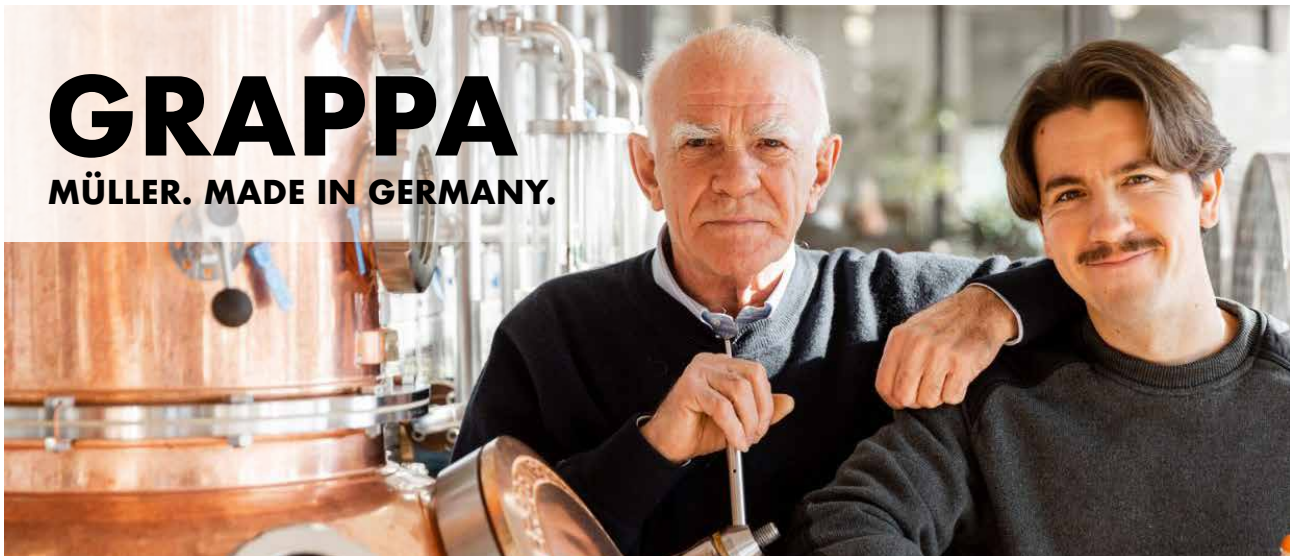



GRAPPA

MÜLLER. MADE IN GERMANY.

In collaboration with the Italian god of grappa, Vittorio Capovilla, our model MÜLLER Grappa is specifically designed for grappa distillers.

The model MÜLLER Grappa operates non-conventionally and with no or only very little addition of water to the pot still. Because thermal ballast is not used, this “dry method” conserves water, time and energy costs. This distillation unit which was designed and engineered with Vittorio Capovilla is perfected for distilling Grappa. It is also just as useful for making fine spirits and for distilling fruits.

PRODUCT SPECIFICATION SHEET — GRAPPA



PRODUCT FEATURES

- 🔥 Large hinged lid for an easy filling
- 🔥 Integrated and removable sieve baskets
- 🔥 Easy emptying with the help of an electrical cable crane
- 🔥 One Pot Still for wash and 2nd distillation
- 🔥 Integrated dephlegmator
- 🔥 All heating solutions available

APPLICATIONS

- 🔥 Grappa / Marc / Pomace
- 🔥 Fruit Brandies

AVAILABLE CAPACITIES

Scalable pot still capacities between 100 – 1,000 litres:

- 🔥 GRAPPA 200
- 🔥 GRAPPA 400
- 🔥 GRAPPA 500
- 🔥 GRAPPA 800
- 🔥 GRAPPA 1000

ALSO CONFIGURABLE AS **CLOSED AND CUSTOM SEALED POT STILL SETUP**





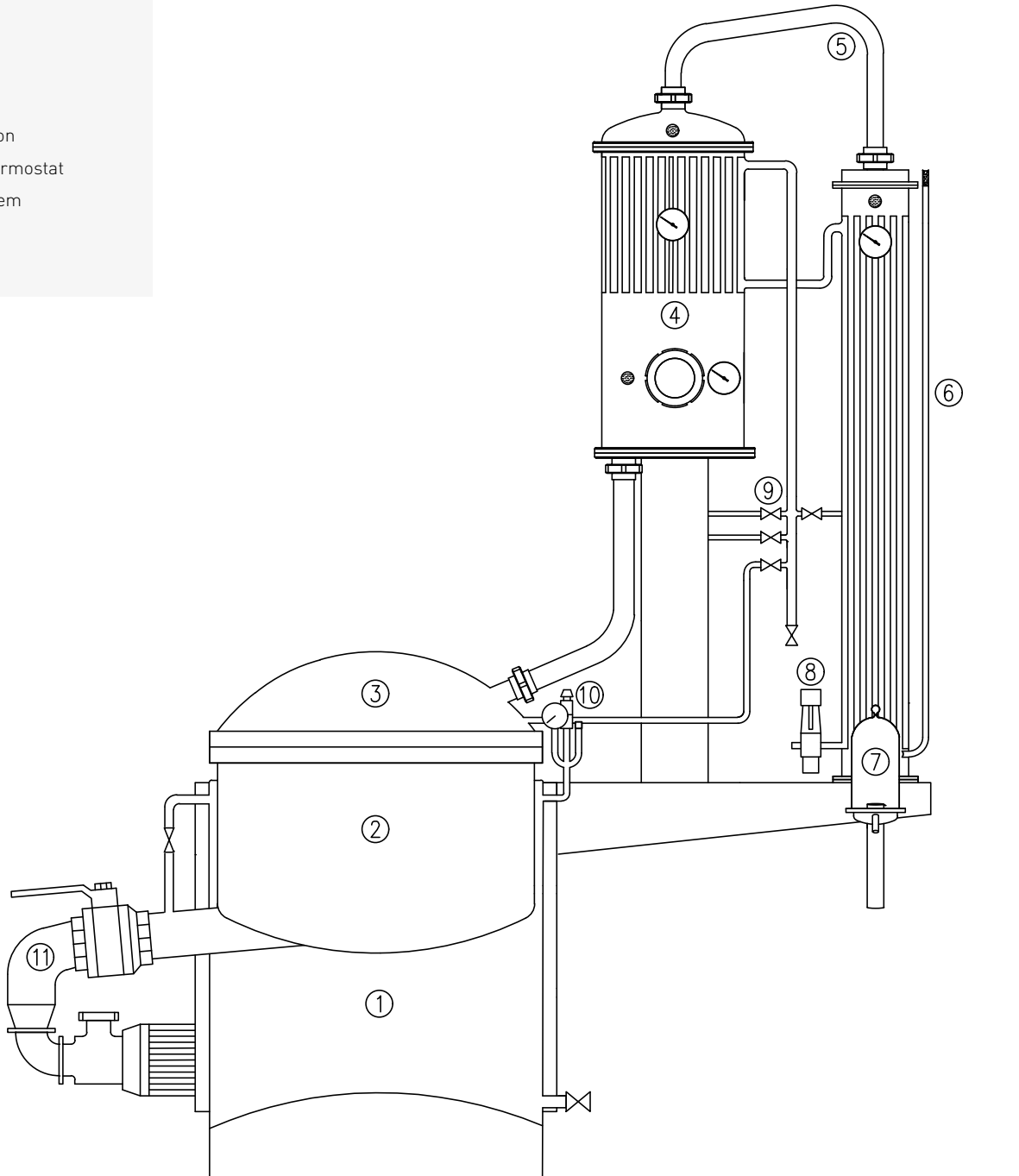







**ENGINEERING
DRAWING GRAPPA**

- 01 Water bath and steam jacket
- 02 Pot Still
- 03 Pot
- 04 Dephlegmator
- 05 Spirit tube
- 06 Condenser
- 07 Alcohol submission
- 08 Cooling water thermostat
- 09 CIP cleaning system
- 10 Safety valve
- 11 Outlet ball valve



PRODUCT LINE AND EQUIPMENT OPTIONS OF THE MÜLLER GRAPPA

The GRAPPA stills by MÜLLER are individually configurable, custom-designed and manufactured to the needs and requirements of the distiller. Here is an overview of some product line and equipment options:

 <p>Pot still capacity 100 – 2,000 litres</p>	 <p>Configurable as AROMÁT & AROMA</p>	 <p>Sight glass and lighting</p>	 <p>Automatic distillation unit controls</p>	 <p>Direct filling</p>	 <p>Ex proof available</p>
 <p>Integrated CIP hot water cleaning technology</p>	 <p>Hot water collection tank with booster pump</p>	 <p>Integrated agitator</p>	 <p>Discharge pump</p>	 <p>Aroma basket</p>	 <p>Distillate separator</p>

PRODUCTS AND EQUIPMENT

Our extensive accessory program contains a variety of parts and products that you as master distiller or wine maker may need. All these accessories are compatible with our pot still systems.

Please contact us, we will be pleased to consult you.
Or check www.accessoires.pot-stills.com for further information.



WE PROVIDE PERSONAL AND CUSTOM ADVICE!

Our MÜLLER quality standard always includes individual and custom advice on your personal project.

WE ARE LOOKING FORWARD TO HEARING FROM YOU.

Call us at **+49 7802 / 93550** or send us an e-mail at **info@brennereianlagen.de**

LEARN MORE ABOUT **PROJECTS & REFERENCES** THAT SUCCESSFULLY USE THE **MÜLLER GRAPPA**



IMPRESSIONS

MÜLLER GRAPPA

Insights into the production in Italy.



more aroma.
since 1929.



CERTIFIED:
ISO9001



POT-STILLS.COM

PROJECTS & REFERENCES

CAPOVILLA

Italy, Bassano del Grappa

With the unparalleled top quality of his products, Vittorio Capovilla has become the undisputed number one among Italian distillers and he is also known far beyond the country's borders. In 2018, he received the "World Spirits Award for his life's work. Together with his daughter Olivia and his grandson Alvise, this family business operates an organic farm alongside the distillery. The signature of their distillate products is the wax seal with handwritten labels and all products are also only available in limited quantities. With his distillates, Capovilla extracts the pure essence of his homegrown organic fruits and of course his grappas. Vittorio has been our friend, partner and contact for our Italian customers for many years. The GRAPPA distillation unit model was developed in collaboration with Vittorio Capovilla. With whom could we have developed this product better than with the „Grappa God“ of Italy?

The distillery is located at the foot of the Monte Grappa in the small town of Rosa. If you follow the scent of the blossoming mountain peach trees, you will reach Villa Dolfin, where Capovilla has set up his distillery. As Müller's first international customer, Vittorio has relied on the quality of Müller pot stills right from the start and today, in addition to his pot still in Italy, he founded distilleries for his rum production on Guadeloupe and Haiti.

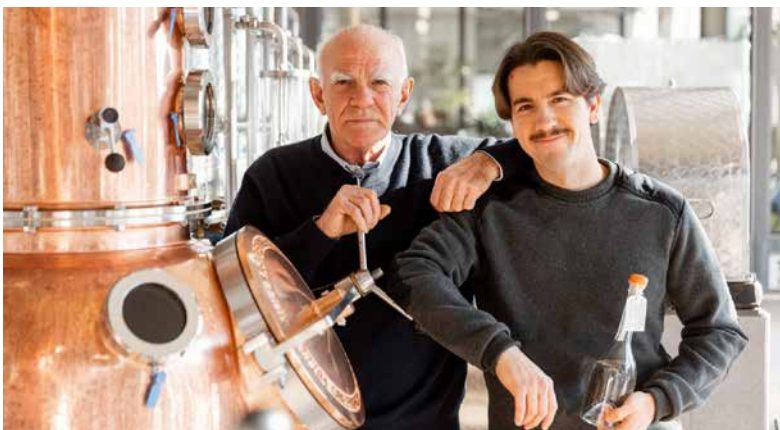

PRODUCTS

🔥 Capovilla Distillati

AWARDS

🔥 World Spirits Award for Lifetime achievements



POT STILLS

from 200 - 1,500 litres Capacity
AROMA and GRAPPA Pot Stills

WWW.CAPOVILLADISTILLATI.IT